

INSTALLASJON

(Koble fra strømforsyningen før installasjon)

1. Skyv innover spennene på begge sider av lampen og fjern monteringsbraketten fra kroppen.
2. Før ekspansjonsrør inn i taket.
3. Fest monteringsbraketten til taket med skruene.
4. Åpne dekselet til koblingsboksen for å koble til ledningene og lukk deretter dekselet.
5. Skyv spennene på lampehuset inn i bøylekroken og sjekk om de er strammet sammen.
6. Installasjonen er ferdig.

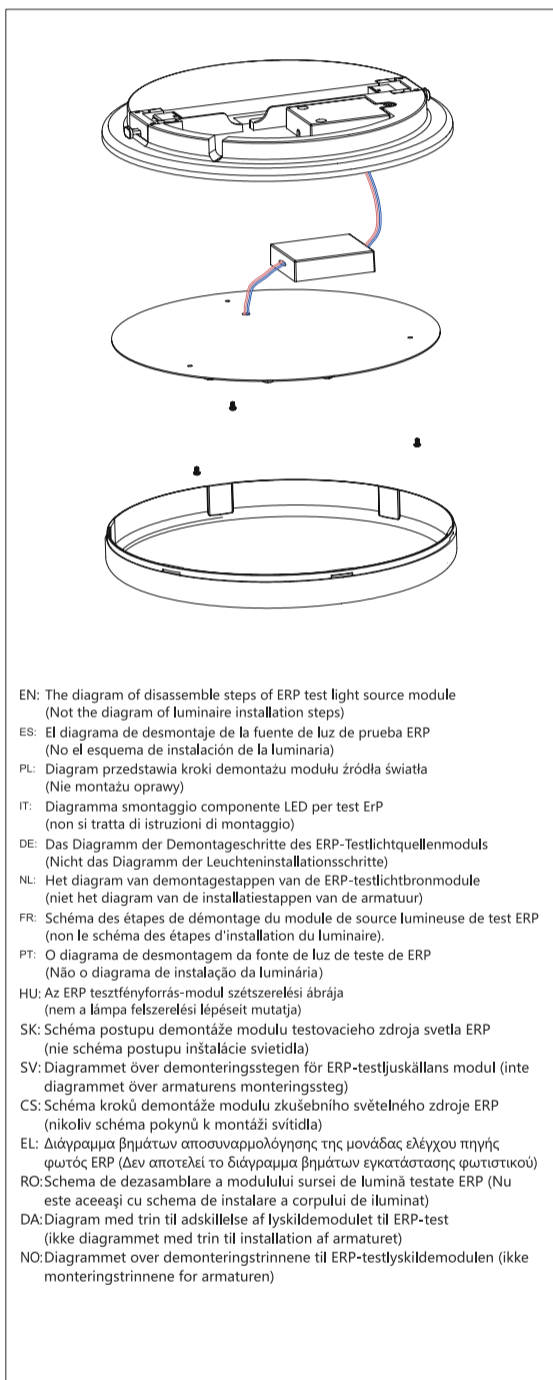
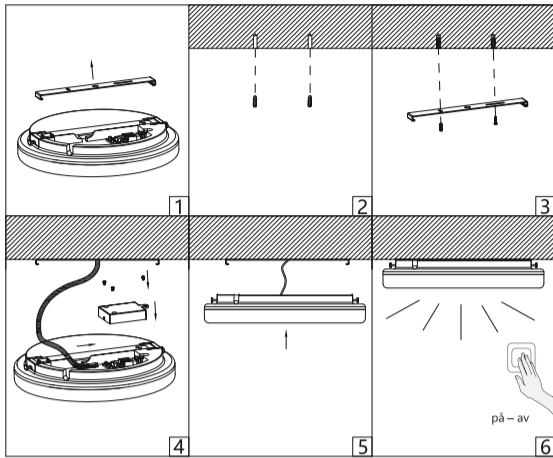

JE-PRCL0220R80L10-18W-30K



JE-PRCL0220R80L10-18W-40K



JE-PRCL0220R80L10-18W-65K



JE-PRCL0280R80L10-24W-30K



JE-PRCL0280R80L10-24W-40K



JE-PRCL0280R80L10-24W-65K



ITALIA MARKET SRL
VIA DELLE INDUSTRIE, 9/1
20883 MEZZAGO(MB), ITALIA
P.IVA: IT10502730962
HTTP://WWW.AIGOSTAR.COM
MADE IN CHINA

